

Description

E2611-LPG is intended for early detection of leakages or accumulation of petroleum gases (butane, propane) in confined spaces.

The instrument is based on fully calibrated and temperature compensated semiconductor metal-oxide gas sensor with high repeatability, stability and long lifetime. The sensor exhibits high sensitivity and selectivity to target gases.

E2611 provides two independent analog outputs OUT1 and OUT2, user-selectable to 4-20 mA or 0-10 V, proportional either to gas concentration or temperature. RS485 Modbus RTU digital communication interface allows easy instrument configuration and integration into various automation systems. Two relays RE1 and RE2 with closing contacts can be used to switch 24 V or 230 V powered alarm sirens, ventilation fans, shut-off valves or other actuators.

Installation and connections

The gas detector should be mounted on a wall at a place located not more than 5 m from possible gas leakage source and not very close to ventilation openings. Since petroleum gases are heavier than air, it is advisable to place LPG Detector not higher than potential gas source, with the sensor pointing downwards. The device should be available for maintenance and repair.

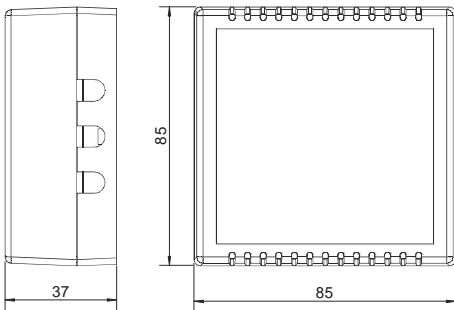
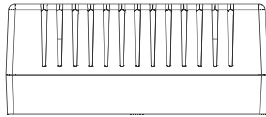

Detach the base of the enclosure by gently pulling along four guiding pins. Fix the base on the wall with two screws. Connect power supply, relay and output cables to the terminal blocks on the PCB and push the enclosure to the base.

To power the instrument from an external 24 VDC source, connect terminals 0 V and +U to the source. If an integrated mains power supply module is used, connect terminals L and N to the mains.

NB! If the instrument is powered from mains, connect to 0 V and +U terminals only light external loads, which consume less than 30 mA in total, as the integrated mains supply module capacity is limited.

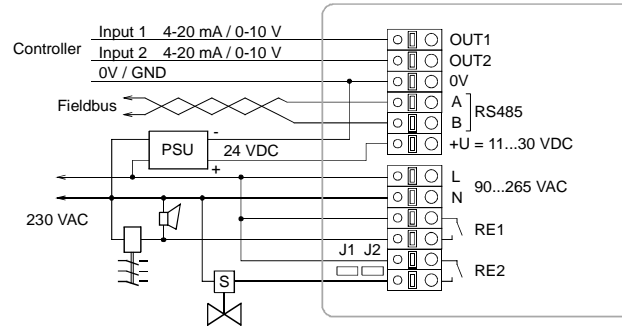

To use analog outputs, connect the terminals OUT1 and/or OUT2 and 0 V to the input of the secondary instrument (indicator or controller).

NB! The outputs are not galvanically isolated from 24 V power supply and share common 0 V. Allowed load resistance limits are stated in Specifications table.

The type of each analog output can be independently selected with the appropriate jumper (J1 for OUT1 and J2 for OUT2). With jumper open, the output type is 4-20 mA. With jumper closed, the output type is 0-10 V.

To use relay outputs, connect the chosen actuators to the relay terminals RE1 and/or RE2.

NB! Actuator short-circuits shall be avoided, to protect the instrument relays use external fuses or safety switches.

Operation

For best stability the gas detector shall be powered permanently. If the instrument is left for a long time in unpowered state, then after initial power-on the metal-oxide gas sensor needs some time to heat up and burn adsorbed contaminants. So for first tens of seconds of few minutes an alarm activation may be possible. After this heating-up period the instrument turns into normal mode.

Configuring

Gas detector E2611 shares all functionalities of the PluraSens® multifunctional transmitter platform. The features and options include:

- digital output change rate limiting filter
- digital integrating (averaging) filter
- temperature measurement channel with internal sensor
- free assignment of each analog output to chosen parameter
- flexible setting of analog output scales for each output
- output shift and slope adjustment for calibration
- free assignment of each of two relays to chosen parameter
- several relay control logic modes (HI or LO with hysteresis, U or П)
- switch delays and minimum on/off state durations for each relay
- Modbus controlled forced state option for analog outputs and relays.

E2611 can be configured through its RS485 interface by Modbus RTU commands. A standard configuration kit includes Model E1087 USB-RS485 converter and E26XX Configurator software.

For procedure details please refer to the configuration manual and protocol description PluraSens_Modbus.

Calibration

E2611-LPG has been calibrated by Manufacturer with standard gas mixtures before delivery. The semiconductor gas sensor exhibits high stability and ~10 year lifetime. However, as the gas sensor is directly exposed to environment, the instrument requires at least annual field recalibration with a portable calibration kit. For procedure details please refer to the calibration manual E26XX_CM. The calibration should be performed by trained specialist.

Warranty

This product is warranted to be free from defects in material and workmanship for a period of one year from the date of original sale. During this warranty period Manufacturer will, at its option, either repair or replace product that proves to be defective. This warranty is void if the product has been operated in conditions outside ranges specified by Manufacturer or damaged by customer error or negligence or if there has been an unauthorized modification.

RS485 communication interface

Databits: 8 Parity: none Stop bits: 1 or 2 Protocol: Modbus RTU	Supported Modbus functions: 03 - read multiple registers 06 - write single register
--	---

Modbus registers (0-based, decimal format)

Reg	Description	Supported values
1	Hardware version	read only
2	Software version	read only
3	Product serial number	read only
4	Slave ID (network address)*	1...247, default 1
5	Baudrate*	1200...57600 baud, default 9600
6	Response delay, ms	1...255 ms, default 10
7	Stop bits*	1 / 2, default 1
17	Restart	write '42330' for soft restart
162	Temperature shift adjustment	-32000...+32000 T units (0,01 °C)
165	Gas channel shift adjustment	-32000...+32000 gas units, default 0
166	Gas channel slope adjustment	1...65535, default 512
167	Output change rate limit	1...32000 gas units/s, 0=no limit
168	Integrating filter time constant	1...32000 s, 0=no, integrating filter
201	Parameter assigned to OUT1	0=none, 1=T, 2=gas, 9=forced by 203
202	Parameter assigned to OUT2	0=none, 1=T, 2=gas, 9=forced by 204
203	Forced value for OUT1	0...1000 (0.0...100.0% of full scale)
204	Forced value for OUT2	0...1000 (0.0...100.0% of full scale)
211	Parameter assigned to RE1	0=none, 1=T, 2=gas, 9=forced by 213
212	Parameter assigned to RE2	0=none, 1=T, 2=gas, 9=forced by 214
213	Forced state for RE1	0=off, 1=on (relay control by Modbus)
214	Forced state for RE2	0=off, 1=on (relay control by Modbus)
215	Switch delay for RE1	0...1000 s, default 0
216	Switch delay for RE2	0...1000 s, default 0
217	Min on/off time for RE1	0...1000 s, default 0
218	Min on/off time for RE2	0...1000 s, default 0
219	Control logic for relay RE1	0:_; 1:_↓↑ · P; 2: · P↑↓_; 3:_↑ · P↓_; 4: · P↓↑ · P
220	Control logic for relay RE2	0:_; 1:_↓↑ · P; 2: · P↑↓_; 3:_↑ · P↓_; 4: · P↓↑ · P
221	LOW setpoint for relay RE1	-32000...+32000, gas or T units
222	HIGH setpoint for relay RE1	-32000...+32000, gas or T units
223	LOW setpoint for relay RE2	-32000...+32000, gas or T units
224	HIGH setpoint for relay RE2	-32000...+32000, gas or T units
258	Measured temperature	-4000...+12500 T units (0,01 °C)

259	Gas concentration	0...65535 gas units
261	0% value of OUT1	-32000...+32000 gas units / integer °C
262	100% value of OUT1	-32000...+32000 gas units / integer °C
263	0% value of OUT2	-32000...+32000 gas units / integer °C
264	100% value of OUT2	-32000...+32000 gas units / integer °C

* - the new value is applied after restart

Broadcast ID=0 may be used to assign a new ID to device with unknown ID

Specifications

Default calibration	isobutane C ₄ H ₁₀
Detection range	0...100% LEL
Resolution	0.1 %LEL
Accuracy	± 5 %LEL
Response time	~15 seconds
Warm-up time	up to 1 minute, depending on unpowered period and atmosphere
Sensor type	semiconducting metal-oxide
lifetime	>10 years
Sampling method	diffusion
Analog outputs	2 × 4-20 mA or 0-10 V
Load resistance	for 4-20 mA output mode: R _L < (U _s - 2 V) / 22 mA for 0-10 V output mode: R _L > 250 kOhm
Operating conditions	-30...+70 °C, 0...95 %RH, without condensation, not ATEX rated areas
Power supply	11...30 VDC with integrated mains supply module 90...265 VAC
Power consumption	< 2 VA
Electromagnetic compatibility	according to Directive 2004/108/EC, 2014/30/EU and EN61326-1 standard requirements
Enclosure	wall-mount, white ABS 85 × 85 × 55 mm, IP20
Relays	2 × SPST, max 5 A, 30 VDC / 250 VAC

Factory settings

Target gas	Butane, propane
Gas units	0.1 % LEL
OUT1 assignment and scale	2: gas, 0 - 100% LEL
OUT2 assignment and scale	2: gas, 0 - 100% LEL
RE1 assignment and logic	2: gas, 1: on at high values
RE1 HIGH setpoint (set)	20% LEL
RE1 LOW setpoint (release)	16% L
RE2 assignment and logic	2: gas, 1: on at high values
RE2 HIGH setpoint (set)	50% LEL
RE2 LOW setpoint (release)	40% LEL



Liquefied petroleum gas detector-transmitter

E2611-LPG

User manual