



# Combustible Gases Transmitter E2617-LEL

*USER MANUAL*

## Table of Contents

Butane	3
Hydrogen	4
Methane	4
Propane	5
Specifications	7
Product Description	8
Safety requirements	8
Operating conditions	8
Installation guidelines	9
Mounting dimensions	10
Electrical connections	11
Delivery set	11
Warranty	12
Manufacturer contacts	12

## Butane

A colorless flammable gas that is heavier than air. The term “butane” is used for any of two structural isomers (n-butane or iso-butane, with unbranched and branched-chain respectively) or for their mixture. Occurs in light petroleum fractions.

Butane is used mainly as a fuel and as a feedstock in organic synthesis. It is applied also as a propellant in aerosol sprays and may be used as an ozone-friendly refrigerant.

Mixtures of butane with propane and other hydrocarbons are referred to as LPG (liquefied petroleum gas).

Chemical formula		n-butane $\text{CH}_3\text{CH}_2\text{CH}_2\text{CH}_3$	iso-butane $\text{CH}_3\text{CH}(\text{CH}_3)\text{CH}_3$
Molar weight		58	
Relative gas density (to air)		2.0	
Conversion		1 ppm = 0.0818 mg/m <sup>3</sup>	
Boiling point		-0.56 °C	-11.7 °C
Low explosive limit (LEL), % vol. in air		1.4* (1.6**)	1.5* (1.8**)
Upper explosive limit (UEL), % vol. in air		8.4	9.6
Odor		Odorless	
Hazards		Highly flammable. Inhalation of butane can cause euphoria, drowsiness, narcosis, asphyxia, cardiac arrhythmia, fluctuations in blood pressure, and temporary memory loss, when abused directly from a highly pressurized container and can result in death from asphyxiation and ventricular fibrillation.	
Exposure limits (NIOSH)	TWA	1900 mg/m <sup>3</sup> /800 ppm	Not established

## Hydrogen

A colorless, odorless, flammable gas that is much lighter than air. Mixtures with air are explosive. Results from the interaction of acids, bases, and water with active metals and from the electrolysis of aqueous solutions. In industrial production, the main source of hydrogen is hydrocarbons.

Chemical formula	H <sub>2</sub>
Molar weight	2
Relative gas density (to air)	0.07
Conversion	1 ppm = 0.0818 mg/m <sup>3</sup>
Boiling point	-252.88 °C
Low explosive limit (LEL), % vol. in air	4.0
Upper explosive limit (UEL), % vol. in air	75
Odor	Odorless
Hazards	Flammable forms explosive mixtures with air. Asphyxiant.
Exposure limits	not established

## Methane

A colorless flammable gas, the main component of natural gas, marsh gases. Methane results from bacterial decomposition of plant and animal matter (landfill gas).

Methane is widely used as a fuel and chemical feedstock

Synonyms: Marsh Gas, Natural Gas, Carbon tetrahydride, Hydrogen carbide

Chemical formula	CH <sub>4</sub>
Molar weight	16
Relative gas density (to air)	0.55
Conversion	1 ppm = 0.65 mg/m <sup>3</sup>
Boiling point	-161.49 °C
Low explosive limit (LEL), % vol. in air	4.4* (5.0**)
Upper explosive limit (UEL), % vol. in air	15
Odor	Odorless when pure. Methane used in the kitchens contains an odorant
Hazards	Highly flammable, mixtures with air are explosive. Asphyxiant
Exposure limits	not established

## Propane

A colorless flammable gas that is heavier than air. It occurs in light petroleum fractions.

Propane is used mainly as a fuel and as a feedstock in organic synthesis. It is applied also as a propellant in aerosol sprays and may be used as an ozone-friendly refrigerant.

Mixtures of propane with butane and other hydrocarbons are referred to as LPG (liquefied petroleum gas).

Chemical formula	C <sub>3</sub> H <sub>8</sub>	
Molar weight	44	
Relative gas density (to air)	1.55	
Conversion	1 ppm = 1.80 mg/m <sup>3</sup>	
Boiling point	-42 °C	
Low explosive limit (LEL), % vol. in air	1.7* (2.1**)	
Upper explosive limit (UEL), % vol. in air	9.5	
Odor	Odorless when pure. Commercially available propane for fuel purposes may contain odorant ("gas smell").	
Hazards	Highly flammable, mixtures with air are explosive. Asphyxiant. May cause dizziness, confusion, excitation when inhaled.	
Exposure limits (NIOSH)	TWA	1800 mg/m <sup>3</sup> /1000ppm
	IDLH	2100 ppm [10%LEL]

Conversion of ppm to mg/m<sup>3</sup> is calculated for 25 °C and 1 atm.

\* according to new EU standards ('stirred' concentration of gas)

\*\* according to US standard ('still gas' method)

## Specifications

Sensor type	Pellistor (Catalytic Bead)
Sampling method	Diffusion
Detection range	0-100 %LEL
Response time T90	≤ 10 s
Sensor protection	Microporous PTFE dust filter
Sensor lifetime	> 3 years *in an appropriate residential or light commercial applications
Sensitivity drift	< ± 5% / year *in an appropriate residential or light commercial applications
Power supply	24VDC ± 20%
Power consumptions	< 1W
Analog output	4-20 mA / 0-10 V, user selectable
Load resistance	RL < (Us - 8 V) / 22 mA for 4-20 mA output RL > 250 kOhm for 0-10 V output
Enclosure	Grey ABS plastic, wall mount, protection class IP65
Dimensions	H82 × W94 × D35
CE marking	According to 2014/30/EU and 2014/35/EU , EN50491-4-1:2012 EN61000-6-3:2007, EN 61326-1:2013(EMC, emissions), EN 61000-6-1:2019 and EN 61000-6-2:2019(EMC, immunity) EN 60079-29-1:2016,EN 60079-29-2:2015 and EN 60079-29-3:2014
Operating conditions	-10...+50°C, 5-95%RH, pressure 900 to 1100 mbar Explosion safe indoor areas Avoid strong mechanical shock, vibrations, or EMI Avoid exposure to corrosive gases <b>NOTE!</b> The sensor may exhibit sensitivity to most combustible gases.

## Product Description

E2617 series gas transmitters are easy-to-install and easy-to-use instruments. The devices utilize fully novel fully calibrated gas sensors with excellent repeatability, stability, and long lifetime.

E2617 series provide an analog output with user-selectable signal type, 4-20 mA or 0-10V.

## Safety requirements

Misuse will impair the protection of the product. Always adhere to the safety provisions applicable in the country of use.

Do not perform any maintenance operation with the power on. Do not let water or foreign objects inside the device.

Removal of the PCB from the enclosure voids the warranty. Do not touch the electronic components directly, as they are sensitive to static electricity.

Connection diagrams can be found in the electrical connections section. The device might not perform correctly or be damaged if the wrong power supply is connected.

External circuits connected to the equipment should have sufficient insulation rating according to the environmental conditions and equipment power.

A disconnecting device that is marked as such and easily accessible should be included in the installation of this product

## Operating conditions

The device should be used both in a non-hazardous area and in a basic electromagnetic environment, where the latter is defined in EN 61326-1. Avoid strong mechanical shock and vibrations. Avoid corrosive atmosphere and areas highly contaminated with dust, oil mist, etc. Keep the instrument away from direct sunlight. A sudden temperature or humidity change might affect the sensitivity of the sensor.



## Installation guidelines

Before proceeding with the installation it is mandatory to read the Safety requirements section and make sure to comply with all listed instructions. Installation standards EN 60079-29-2 and EN 45544-4 are also recommended for further instructions and related information about the installation. During the installation of the transmitter the following points must be considered:

- Application (the instrument is intended for air quality or leakage control).
- Properties of the space under investigation (room geometry, direction, and velocity of airflows, etc.).
- Methane and hydrogen are lighter than air and tend to rise. It is recommended to place the transmitter higher than potential leakage/generation source or near the ceiling.
- Propane and butane are heavier than air and tend to sink. It is recommended to place the sensor lower than potential leakage/generation source or near the floor.
- The device should be accessible for maintenance / calibration.

The aforementioned conditions above will affect the coverage area of the device. However, the coverage area for a transmitter is usually between 2.5 to 5 meters radius.

For early leakage detection, install the transmitter as close as possible to the potential leakage sources (flanges, valves, pressure reducers, pumps, etc.), taking into consideration other points listed above.

For general area monitoring without definite leakage sources, the transmitters should be distributed evenly in the room.

For personal safety control, the transmitters are installed in the breathing zone (at the height of the head of people or animals).

For installing the device, attach the device to the wall using provided screws through the key slots on both sides of the device.

## Mounting dimensions

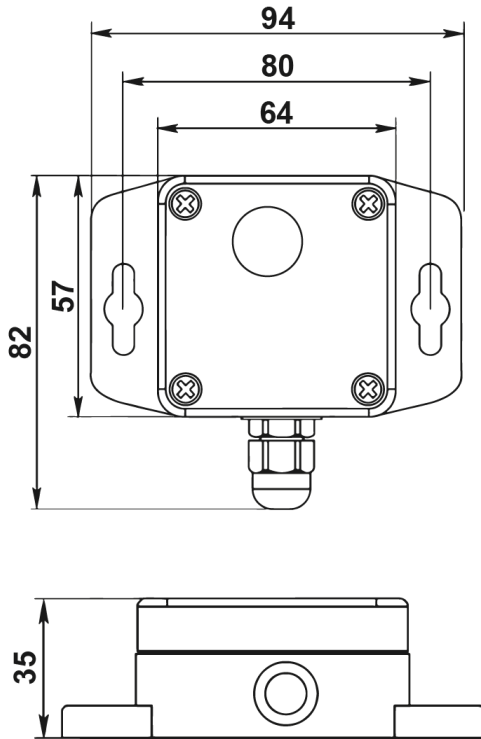

The IP65 instrument sensor is equipped with a hydrophobic microporous PTFE filter to protect the sensor from dust, dirt, and water drops.

**NOTE!** Never stab or press the filter near its center where the sensor is located since this may damage the sensor. Do not remove the filter as it may cause the device to show incorrect values.

## Electrical connections

### 3-wire 4-20 mA output

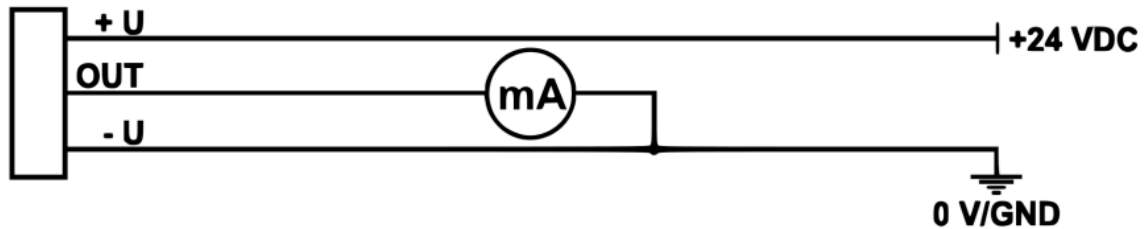

### 3-wire 0-10 V output

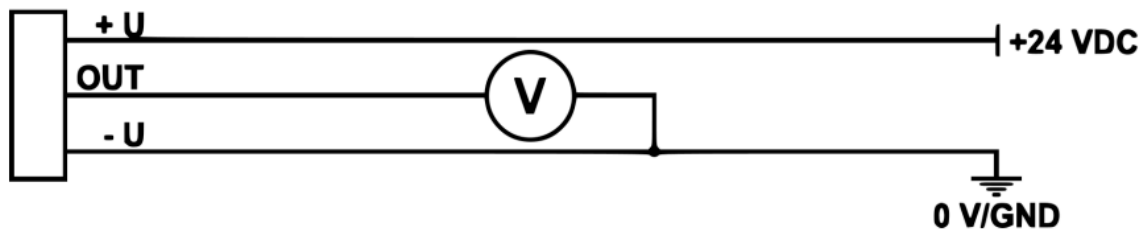

The terminals on the E2617 series devices are suitable for a wide range of wires with a cross-section of 0.34...2.5 mm<sup>2</sup>. We recommend to strip the wire end by 8...9 mm and use wire end sleeves.

To connect the wire, loosen the screw, insert the wire end into the terminal hole and tighten the screw.

The analog output can be changed between 4-20 mA and 0-10 V type using jumper on the transmitter's PCB.

## Delivery set

- Transmitter E2617-LEL
- Mounting accessories:
  - 2 screws with plastic dowels

## Warranty

This product is warranted to be free from defects in material and workmanship for a period of one year from the date of the original sale. During this warranty period, the Manufacturer will, at its option, either repair or replace a product that proves to be defective. This warranty is void if the product has been operated in conditions outside ranges specified by the Manufacturer or damaged by customer error or negligence or if there has been an unauthorised modification.

## Manufacturer contacts

Evikon MCI OÜ

Teaduspargi 9, Tartu  
50411 Estonia  
info@evikon.eu  
www.evikon.eu