



Carbon Monoxide Detector

E2630-CO

User Manual



Table of contents

Carbon Monoxide	3
Specifications	4
Product description	5
Safety requirements	5
Operating conditions	5
Installation guidelines	6
Mounting dimensions	7
Connections	8
Operation	10
Sensor probe handling	11
The electrochemical gas sensor replacement procedures	11
Maintenance	12
Calibration	12
Delivery set	12
Order code for E2630-CO options	12
Warranty	13
Manufacturer contacts	13

Carbon Monoxide

A Colorless, odorless, and tasteless gas that is highly toxic. Carbon monoxide is formed as a result of incomplete combustion of carbon-containing compounds, e.g. while operating a furnace, an oven, or an engine when there is a limited supply of air.

Synonyms: Carbonous oxide, Carbon (II) oxide, Flue gas, Monoxide

Chemical formula		CO
Molar weight		28
Relative gas density (to air)		0,97
Conversion		1 ppm= 1.15 mg/m ³
Boiling point		-191.5 °C
Low explosive limit (LEL), % vol. in air		12.5
Upper explosive limit (UEL), % vol. in air		74
Odor		odorless
Hazards		Highly toxic. Mild poisoning causes lightheadedness, confusion, headache, dizziness, and flu-like effects. Larger exposures can lead to toxicity of the CNS and heart, and death. After acute poisoning, long-term problems may occur. CO also has negative effects on a baby if exposed during pregnancy. Chronic exposure to low levels can lead to depression, confusion, and memory loss.
Exposure limits (ACGIH)	TWA	40 mg/m ³ /35 ppm
	STEL	1380 mg/m ³ /1200 ppm

Conversion of ppm to mg/m³ is calculated for 25°C and 1 atm.

Specifications

Sensor type	Electrochemical cell	
Sampling method	Diffusion	
Typical detection range	0...200 ppm	0...1000 ppm
Alarm setpoints (release-LOW-HIGH)	18 - 25 - 125 ppm	88 - 125 - 250 ppm
Response time T90	< 30 seconds	
Signal update	Every 1 second	
Sensor lifetime	> 10 years	
Calibration interval	12 months	
Power supply	24 VAC/DC or 90...265 VAC	
Power consumption	< 2 VA	
Digital interface	UART	
Relay outputs	2 × SPDT, max 5 A, 30 VDC / 250 VAC	
Alarm signaling	Buzzer 2 kHz, 85 dB; red LED	
LEDs	Green/red (operation/fault), red (gas alarm)	
Enclosure	Grey ABS, wall mount, protection class IP65	
Dimensions	H140 × W145 × D55 mm	
CE marking	According to 2014/30/EU and 2014/35/EU, EN 50491-4-1:2012 EN 61000-6-3:2020, EN 61326-1:2013(EMC, emissions) EN 61000-6-1:2019, EN 61000-6-2:2019(EMC, Immunity) EN 60079-29-1:2016, EN 60079-29-2:2015 and EN 60079-29-3:2014	
Operating conditions	-20...+50 °C, 0...90% RH non-condensing, 0,9...1,1 atm Explosion safe indoor areas, Non-aggressive atmosphere NOTE! The sensor may exhibit sensitivity to acetylene, ethylene, hydrogen, and nitric oxide.	

Product description

E2630 series gas detectors are compact and easy-to-use instruments. The devices utilize novel fully calibrated and temperature compensated gas sensors with excellent repeatability, stability, and long lifetime.

Two relays RE1 and RE2 with switching contacts can be used to control alarm sirens, ventilation fans, shut-off valves, or other actuators. The devices are equipped with a visual and acoustic alarm.

The version of your detector is marked on the package.

Safety requirements

Misuse will impair the protection of the product. Always adhere to the safety provisions applicable in the country of use.

Do not perform any maintenance operation with the power on. Do not let water or foreign objects inside the device.

Removal of the PCB from the enclosure voids the warranty. Do not touch the electronic components directly, as they are sensitive to static electricity.

Connection diagrams can be found in the connections section. The device might not perform correctly or be damaged if the wrong power supply is connected.

External circuits connected to the equipment should have sufficient insulation rating according to the environmental conditions and equipment power.

A disconnecting device that is marked as such and easily accessible should be included in the installation of this product.

Operating conditions

The device should be used both in a non-hazardous indoor area and in a basic electromagnetic environment, where the latter is defined in EN 61326-1. Avoid strong mechanical shock and vibrations. Avoid corrosive atmosphere and areas highly contaminated with dust, oil mist, etc. Keep the instrument away from direct sunlight. A sudden temperature or humidity change might affect the sensitivity of the sensor.

When stored without powering in normal air for a long period, or in an environment contaminated with organic vapors or volatile oils, the sensor may show a reversible drift in resistance according to the environment.

Installation guidelines

There are no precise rules or standards to follow when installing gas detectors. The following points must be taken into account:

- Application (air quality control or leakage detection.)
- Properties of the space under investigation (room geometry, direction, and velocity of airflows, etc.),
- Carbon monoxide has practically the same density as air and spreads evenly in the room. Install the sensor in proximity to possible leakage or generation source, taking into consideration the temperature of the gas, the air currents in the room, etc.
- The device should be accessible for maintenance and repair.

The aforementioned conditions above will affect the coverage area of the device. however, the coverage area for a detector is usually between 2.5 to 5 meters radius.

For early leakage detection install the sensor as close as possible to the potential leakage sources (flanges, valves, pressure reducers, pumps, etc.), taking into consideration other points listed above.

For general area monitoring without definite leakage sources, the detector should be distributed evenly in the room.

Do not locate the detector close to ventilation openings and strong air currents. Avoid the areas without air circulation (corners, niches) as well.

For personal safety control, the detectors are installed in the breathing zone (at the height of the head of people or animals). The recommended sensor position is vertical, pointing downwards.

Mounting dimensions

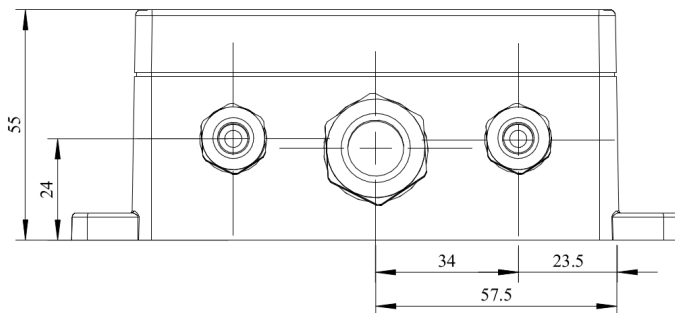
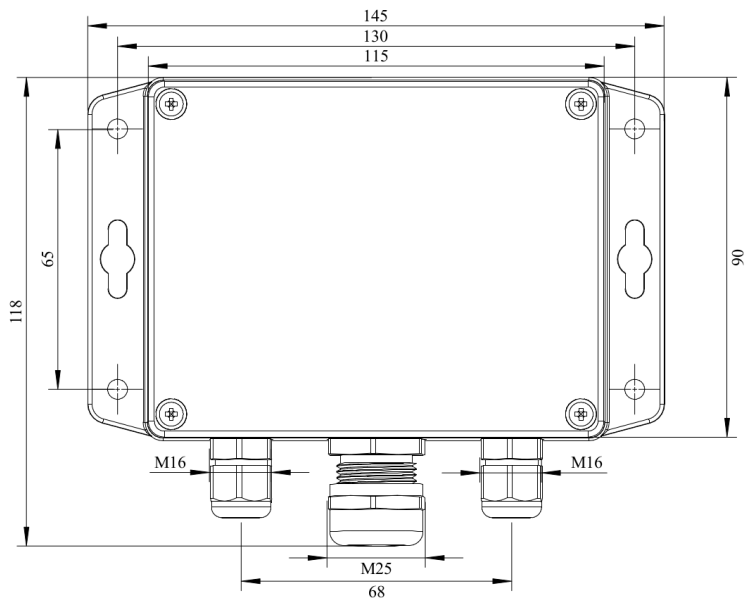

Connections

1. Unscrew four lid screws and detach the lid from the device;
2. Attach the device to the wall using provided screws through the side mounting holes or key slots (This step may be done before step 1, consider your convenience).
3. Use two M16 cable glands to let in the cables of the power supply and of the external devices.

Connect the power terminals N and L to the 24 V power source if you are using detector version -24 or to 230 V AC mains if you are using detector version -230 (see diagram below).

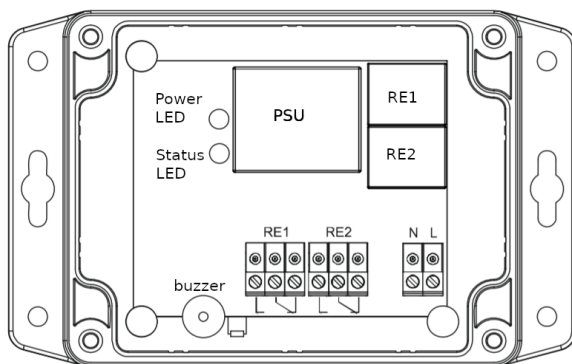

Terminals	
RE1 NO	Relay 1, normally open terminal
RE1 COM	Relay 1, common terminal
RE1 NC	Relay 1, normally closed terminal
RE2 NO	Relay 2, normally open terminal
RE2 COM	Relay 2, common terminal
RE2 NC	Relay 2, normally closed terminal
L	90...265 VAC Phase (optional 24 VAC / VDC)
N	90...265 VAC Neutral (optional 24 VAC / VDC)

The terminals on the E2630 series devices are suitable for a wide range of wires with cross-section 0,2...1,5 mm². We recommend to strip the wire end by 5..6 mm and use the wire end sleeves. To connect the wire, loosen the screw, insert the wire end into the terminal hole and tighten the screw. The outer diameter of the cable must not exceed 8 mm.

To use relay outputs, connect the chosen actuators to the relay terminals RE1 and/or RE2.

NOTE! Actuator short-circuits shall be avoided. To protect the instrument relays, use external fuses or safety switches.

3. Place the lid back and fix it with the screws. Make certain that the cable glands are properly tightened to ensure the conformity to IP65 protection class.

4. Turn on the power. It may take up to five minutes after switching on for the sensor to stabilize.

For stable operating, it is recommended to keep the detector powered constantly, except for periods of maintenance, calibration, replacement, etc.

Operation

During the first ca. 60 seconds after powering on E2630 performs a warming-up and self-diagnostic routine, indicated by the flashing of each LED. The upper dual-color LED remains continuously green in normal operation and blinks red in case of device or sensor fault. The warm-up time depends on the sensor type, unpowered period, and atmosphere.

During the first 30 seconds after powering on you may select the automatic or manual mode of alarm release. Touch the device with the magnet key on the spot shown in the drawing below.

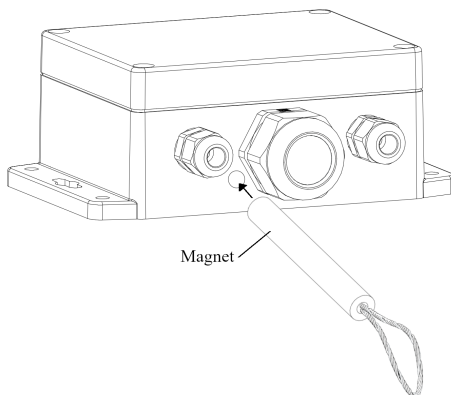

A short touch (< 2 s) enables the automatic mode, a touch of 2...10 s – manual mode. The activation of the automatic mode is followed by a single LED blinking and acoustic signal. If manual mode is activated, the double acoustic and light signal follows.

If the gas concentration exceeds the LOW alarm setpoint, the bottom red LED starts flashing at a rate of 1 Hz, and the relay RE1 switches over. The first alarm stops automatically if the gas concentration drops below 70% of the LOW alarm setpoint.

If the gas level exceeds the HIGH alarm setpoint, the bottom red LED starts flashing and the buzzer starts beeping at a rate of 2 Hz, and also the relay RE2 switches over. Depending on the selected release mode, the HIGH alarm stops automatically or can be stopped with a short touch of the magnet key, if the gas level has dropped below 70% of the LOW alarm setpoint. Upon contact, the key should activate the reed switch located left of the sensor inside the device.

Apart from the warming-up period, a 2....10 s touch causes the device to reset and perform the self-diagnostic routine for testing purposes. To check the visual and acoustic alarm, touch the device with the magnet key for more than 10 s. This will launch blinking and beeping (stops as soon as the key is withdrawn).

Sensor probe handling

The sensor probes of all types are equipped with a hydrophobic microporous PTFE filter to protect the sensor from dust, dirt, and water drops. The filter may be replaced if it gets strongly contaminated. To replace the PTFE filter, unscrew the sensor head cap and remove the old filter. Place a new filter into the cap and tighten it again.

NOTE! Never stab or press the filter near its center where the sensor is located since this may damage the sensor. Do not remove the filter as it may cause the device to show incorrect values and/or break the sensor.

The recommended orientation of the sensor probe is vertical with the sensor tip pointing downwards. This prevents the possible accumulation of condensed water on the sensor protection filter.

The electrochemical gas sensor replacement procedures

1. Un-power detector;
2. Unscrew sensor head cap;
3. Carefully take out the sensor cell;
4. Disconnect the first wire from the old sensor and connect to the same pin on the new sensor;
5. Disconnect the second wire from the old sensor and connect to the second pin on the new sensor;
6. Insert the new sensor into the sensor head and screw back the sensor head cap.

Maintenance

Do not perform any maintenance operation with the power on.

Clean the device with a soft damp cloth. Do not use any abrasive cleaning agents. Do not immerse the device in water or any cleaning media.

Calibration

E2630-CO detectors have been calibrated by the Manufacturer with standard gas mixtures before delivery. Provided that the sensor is used under moderate conditions, field recalibration is recommended every 12 months. Please contact your dealer for more information.

Delivery set

- Carbon Monoxide Detector E2630-CO
- Mounting accessories:
 - 4 screws and 4 plastic dowel plugs

Order code for E2630-CO options

E2630 options	Order code
Integrated 90...265 V mains power supply module	E2630-CO-230
Integrated 24 VAC power supply module	E2630-CO-24VAC

Warranty

This product is warranted to be free from defects in material and workmanship for a period of one year from the date of the original sale. During this warranty period, the Manufacturer will, at its option, either repair or replace a product that proves to be defective. This warranty is void if the product has been operated in conditions outside ranges specified by the Manufacturer or damaged by customer error or negligence or if there has been an unauthorized modification.

Manufacturer contacts

Evikon MCI OÜ

Teaduspargi 7/9, Tartu

50411 Estonia

info@evikon.eu

www.evikon.eu

