



# Solvent Vapor Detector

**E2630-VOC**

User Manual



# Table of contents

Acetone	3
Benzene	4
Ethanol	5
Ethyl acetate	6
Toluene	7
Xylene	8
Specifications	9
Product description	10
Safety requirements	10
Operating conditions	10
Installation guidelines	11
Mounting dimensions	12
Connections	13
Operation	15
Sensor probe handling	16
Maintenance	17
Calibration	17
Delivery set	17
Order code for E2630-VOC options	17
Warranty	18
Manufacturer contacts	18

## Acetone

A colorless organic solvent with a characteristic pungent odor that is volatile and flammable with the chemical formula  $(\text{CH}_3)_2\text{CO}$ .

Synonyms/Trade Names: Dimethyl ketone, Ketone propane, 2-Propanone.

Chemical formula	$(\text{CH}_3)_2\text{CO}$	
Molar weight	58	
Relative gas density (to air)	2.0	
Conversion*	1 ppm = 2.38 mg/m <sup>3</sup>	
Boiling point	56.11 °C	
Low explosive limit (LEL), % vol. in air	2.5	
Upper explosive limit (UEL), % vol. in air	12.8	
Odor	Characteristic pungent smell	
Hazards	Highly flammable. Slightly toxic in normal use. Irritant causing mild skin irritation and moderate to severe eye irritation. At high vapor concentrations, it may depress the CNS.	
Exposure limits	8 hours (2000/39/EC)	1900 mg/m <sup>3</sup> / 500 ppm
	NIOSH REL TWA	590 mg/m <sup>3</sup> /250 ppm
	IDLH (NIOSH)	2500 ppm [10%LEL]

## Benzene

A colorless liquid with an aromatic odor that is highly flammable with the molecular formula  $C_6H_6$ .

Synonyms/Trade Names: Benzol, Phenyl hydride.

Chemical formula		$C_6H_6$ 
Molar weight		78
Relative gas density (to air)		2.69
Conversion*		1 ppm = 3.19 mg/m <sup>3</sup>
Boiling point		80 °C
Low explosive limit (LEL), % vol. in air		1.2
Upper explosive limit (UEL), % vol. in air		7.8
Odor		Hyacinth-like odor
Hazards		Highly flammable. Irritant. Carcinogen. May cause dizziness; headache, nausea, staggering gait; anorexia, lassitude. Target organs: eyes, skin, respiratory system, blood, central nervous system, bone marrow.
Exposure limits (NIOSH REL)	Ca TWA	0.319 mg/m <sup>3</sup> /0.1 ppm
	STEL 15 minutes	1 ppm
	Ca IDLH	500 ppm

## Ethanol

A clear colorless liquid with a faintly sweet odor and pungent taste.

Synonyms/Trade Names: ethyl, alcohol.

Chemical formula	CH <sub>3</sub> CH <sub>2</sub> OH	
Molar weight	46	
Relative gas density (to air)	1,59	
Conversion*	1 ppm = 1.89 mg/m <sup>3</sup>	
Boiling point	78.37°C	
Low explosive limit (LEL), % vol. in air	3 - 3.3	
Upper explosive limit (UEL), % vol. in air	19	
Odor	The characteristic smell of alcohol	
Hazards	Highly flammable. Gas/air mixtures are explosive. Inhalation of vapors leads to cough, headache, fatigue, and drowsiness. High concentrations may damage the fetus. Repeated high exposure may affect the liver and the nervous system.	
Exposure limits according to Commission Directive 2006/15/EC	TWA 8 hours	1210 mg/m <sup>3</sup> / 1000 ppm
	STEL 15 minutes	-

## Ethyl acetate

A colorless organic compound with a sweet pear-like smell that is highly flammable.

Synonyms/Trade Names: ethyl ester, acetic ester, EA, EtOAc.

Chemical formula	$C_4H_8O_2$		
Molar weight			88
Conversion*			1 ppm = 3.60 mg/m <sup>3</sup>
Boiling point			77.1 °C
Low explosive limit (LEL), % vol. in air			2
Upper explosive limit (UEL), % vol. in air			11.5
Odor			Sweet "pear" smell
Hazards			Flammable. Short-term exposure to high levels of ethyl acetate results first in irritation of the eyes, nose, and throat, followed by headache, nausea, vomiting, sleepiness, and unconsciousness.
Exposure (NIOSH) limits	TWA 8 hours	1400 mg/m <sup>3</sup> /400 ppm	
	IDLH	2000 ppm [10%LEL]	

## Toluene

A clear, colorless liquid with a sweet smell that is highly flammable.

Synonyms/Trade Names: methylbenzene, phenylmethane.

Chemical formula	$C_6H_5CH_3$		
Molar weight			92
Conversion*			1 ppm = 3.77 mg/m <sup>3</sup>
Boiling point			110.7°C
Low explosive limit (LEL), % vol. in air			1.1 - 1.27
Upper explosive limit (UEL), % vol. in air			6.75–7.1
Odor			Characteristic "chemical" smell
Hazards			Highly flammable. Gas/air mixtures are explosive. Inhalation possible effects: irritation eyes, nose; lassitude (weakness, exhaustion), confusion, euphoria, dizziness, headache; dilated pupils, lacrimation (discharge of tears); anxiety, muscle fatigue, insomnia; paraesthesia; dermatitis; liver, kidney damage
Exposure limits according to Commission Directive 2006/15/EC	TWA	192 mg/mm <sup>3</sup> / 50 ppm	
	STEL	384 mg/mm <sup>3</sup> / 100 ppm	

## Xylene

A colorless, flammable liquid with a chemical smell. Xylenes are produced by the methylation of toluene and benzene.

The term is used for any of three isomers of dimethylbenzene, or a combination thereof.

Synonyms/Trade Names: xylol, dimethylbenzene.

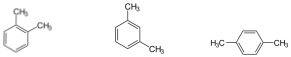
Chemical formula	$C_6H_4(CH_3)_2$		
Isomers	 <i>ortho-xylene</i> <i>meta-xylene</i> <i>para-xylene</i>		
Molar weight	106		
Conversion*	1 ppm = 4.34 mg/m <sup>3</sup>		
Boiling point	144.4 °C	139 °C	138.35 °C
Low explosive limit (LEL), % vol. in air	0.9 - 1.1		
Upper explosive limit (UEL), % vol. in air	6.0–7.0		
Odor	Characteristic “chemical” smell		
Hazards	Flammable. Inhaling can cause dizziness, headache, drowsiness, and nausea.		
Exposure limits according to Commission Directive 2000/39/EC	TWA 8 hours	221 mg/mm <sup>3</sup> / 50 ppm	
	STEL 15 minutes	442 mg/mm <sup>3</sup> / 100 ppm	

Conversion of ppm to mg/m<sup>3</sup> is calculated for 25°C and 1 atm.



## Specifications

Default calibration	Toluene	
Sensor type	Metal Oxide Semiconductor	
Sampling method	Diffusion	
Typical detection range	0...100% LEL	0...500 ppm
Alarm setpoints (release-LOW-HIGH)	7 - 10 - 25 %LEL	70 - 100 - 300 ppm
Response time	< 120 s	
Signal update	Every 1 second	
Sensor lifetime	> 5 years	
Calibration interval	12 months	
Power supply	24 VAC/DC or 90...265 VAC	
Power consumption	< 2 VA	
Digital interface	UART	
Relay outputs	2 × SPDT, max 5 A, 30 VDC / 250 VAC	
Alarm signaling	Buzzer 2 kHz, 85 dB; red LED	
LEDs	Green/red (operation/fault), red (gas alarm)	
Enclosure	Grey ABS, wall mount, protection class IP65	
Dimensions	H90 × W145 × D55 mm (overall dimensions H140 × W145 × D55 mm)	
CE marking	According to 2014/30/EU and 2014/35/EU, EN 50491-4-1:2012 EN 61000-6-3:2020, EN 61326-1:2013(EMC, emissions) EN 61000-6-1:2019, EN 61000-6-2:2019(EMC, Immunity) EN 60079-29-1:2016, EN 60079-29-2:2015 and EN 60079-29-3:2014	
Operating conditions	-40...+70°C, <95% RH non-condensing, 0,9...1,1 atm Explosion safe indoor areas Normal ambient oxygen level	

## Product description

E2630 series gas detectors are compact and easy-to-use instruments. The devices utilize novel fully calibrated and temperature compensated gas sensors with excellent repeatability, stability, and long lifetime.

Two relays RE1 and RE2 with switching contacts can be used to control alarm sirens, ventilation fans, shut-off valves, or other actuators. The devices are equipped with a visual and acoustic alarm.

The version of your detector is marked on the package.

## Safety requirements

Misuse will impair the protection of the product. Always adhere to the safety provisions applicable in the country of use.

Do not perform any maintenance operation with the power on. Do not let water or foreign objects inside the device.

Removal of the PCB from the enclosure voids the warranty. Do not touch the electronic components directly, as they are sensitive to static electricity.

Connection diagrams can be found in the connections section. The device might not perform correctly or be damaged if the wrong power supply is connected.

External circuits connected to the equipment should have sufficient insulation rating according to the environmental conditions and equipment power.

A disconnecting device that is marked as such and easily accessible should be included in the installation of this product.

## Operating conditions

The device should be used both in a non-hazardous indoor area and in a basic electromagnetic environment, where the latter is defined in EN 61326-1. Avoid strong mechanical shock and vibrations. Avoid corrosive atmosphere and areas highly contaminated with dust, oil mist, etc. Keep the instrument away from direct sunlight. A sudden temperature or humidity change might affect the sensitivity of the sensor.

When stored without powering in normal air for a long period, or in an environment contaminated with organic vapors or volatile oils, the sensor may show a reversible drift in resistance according to the environment.

## Installation guidelines

There are no precise rules or standards to follow when installing gas detectors. The following points must be taken into account:

- Application (air quality control or leakage detection.)
- Properties of the space under investigation (room geometry, direction, and velocity of airflows, etc.),
- Solvent vapors are heavier than air, so the gas detector-transmitter should be placed near the floor or potential leakage or formation source.
- The device should be accessible for maintenance and repair.

The aforementioned conditions above will affect the coverage area of the device. however, the coverage area for a detector is usually between 2.5 to 5 meters radius.

For early leakage detection install the sensor as close as possible to the potential leakage sources (flanges, valves, pressure reducers, pumps, etc.), taking into consideration other points listed above.

For general area monitoring without definite leakage sources, the detector should be distributed evenly in the room.

Do not locate the detector close to ventilation openings and strong air currents. Avoid the areas without air circulation (corners, niches) as well.

For personal safety control, the detectors are installed in the breathing zone (at the height of the head of people or animals). The recommended sensor position is vertical, pointing downwards.

## Mounting dimensions

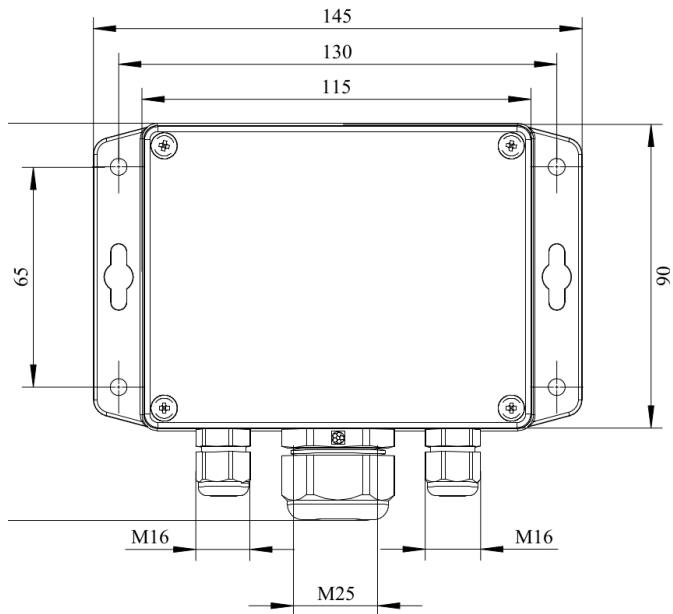

Front view

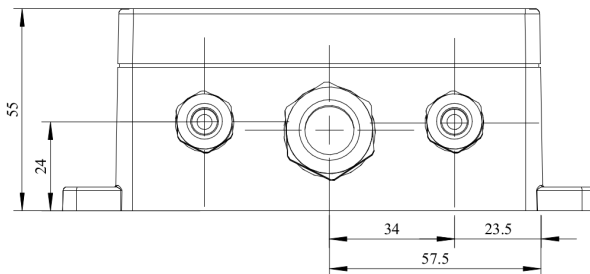

Bottom view

## Connections

1. Unscrew four lid screws and detach the lid from the device;
2. Attach the device to the wall using provided screws through the side mounting holes or key slots (This step may be done before step 1, consider your convenience).
3. Use two M16 cable glands to let in the cables of the power supply and of the external devices.

Connect the power terminals N and L to the 24 V power source if you are using detector version -24 or to 230 V AC mains if you are using detector version -230 (see diagram below).

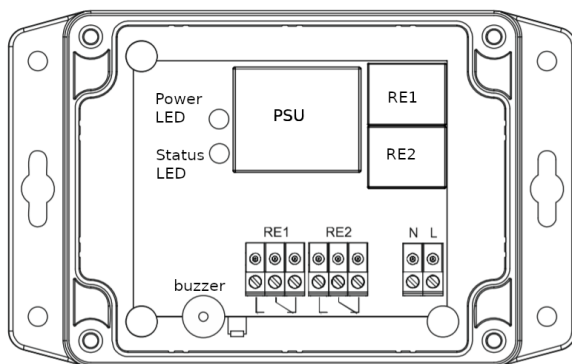

Terminals	
<b>RE1 NO</b>	Relay 1, normally open terminal
<b>RE1 COM</b>	Relay 1, common terminal
<b>RE1 NC</b>	Relay 1, normally closed terminal
<b>RE2 NO</b>	Relay 2, normally open terminal
<b>RE2 COM</b>	Relay 2, common terminal
<b>RE2 NC</b>	Relay 2, normally closed terminal
<b>L</b>	90...265 VAC Phase (optional 24 VAC / VDC)
<b>N</b>	90...265 VAC Neutral (optional 24 VAC / VDC)

The terminals on the E2630 series devices are suitable for a wide range of wires with cross-section 0,2...1,5 mm<sup>2</sup>. We recommend to strip the wire end by 5..6 mm and use the wire end sleeves. To connect the wire, loosen the screw, insert the wire end into the terminal hole and tighten the screw. The outer diameter of the cable must not exceed 8 mm.

To use relay outputs, connect the chosen actuators to the relay terminals RE1 and/or RE2.

**NOTE!** Actuator short-circuits shall be avoided. To protect the instrument relays, use external fuses or safety switches.

3. Place the lid back and fix it with the screws. Make certain that the cable glands are properly tightened to ensure the conformity to IP65 protection class.

4. Turn on the power. It may take up to five minutes after switching on for the sensor to stabilize.

For stable operating, it is recommended to keep the detector powered constantly, except for periods of maintenance, calibration, replacement, etc.

## Operation

During the first ca. 60 seconds after powering on E2630 performs a warming-up and self-diagnostic routine, indicated by the flashing of each LED. The upper dual-color LED remains continuously green in normal operation and blinks red in case of device or sensor fault. The warm-up time depends on the sensor type, unpowered period, and atmosphere.

During the first 30 seconds after powering on you may select the automatic or manual mode of alarm release. Touch the device with the magnet key on the spot shown in the drawing below.

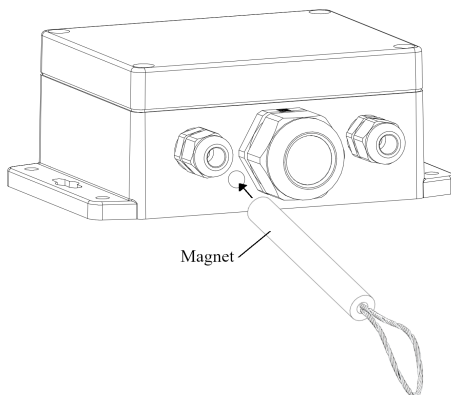

A short touch (< 2 s) enables the automatic mode, a touch of 2...10 s – manual mode. The activation of the automatic mode is followed by a single LED blinking and acoustic signal. If manual mode is activated, the double acoustic and light signal follows.

If the gas concentration exceeds the LOW alarm setpoint, the bottom red LED starts flashing at a rate of 1 Hz, and the relay RE1 switches over. The first alarm stops automatically if the gas concentration drops below 70% of the LOW alarm setpoint.

If the gas level exceeds the HIGH alarm setpoint, the bottom red LED starts flashing and the buzzer starts beeping at a rate of 2 Hz, and also the relay RE2 switches over. Depending on the selected release mode, the HIGH alarm stops automatically or can be stopped with a short touch of the magnet key, if the gas level has dropped below 70% of the LOW alarm setpoint. Upon contact, the key should activate the reed switch located left of the sensor inside the device.

Apart from the warming-up period, a 2....10 s touch causes the device to reset and perform the self-diagnostic routine for testing purposes. To check the visual and acoustic alarm, touch the device with the magnet key for more than 10 s. This will launch blinking and beeping (stops as soon as the key is withdrawn).

## Sensor probe handling

The sensor probes of all types are equipped with a hydrophobic microporous PTFE filter to protect the sensor from dust, dirt, and water drops. The filter may be replaced if it gets strongly contaminated. To replace the PTFE filter, unscrew the sensor head cap and remove the old filter. Place a new filter into the cap and tighten it again.

**NOTE!** Never stab or press the filter near its center where the sensor is located since this may damage the sensor. Do not remove the filter as it may cause the device to show incorrect values and/or break the sensor.

The recommended orientation of the sensor probe is vertical with the sensor tip pointing downwards. This prevents the possible accumulation of condensed water on the sensor protection filter.

**NOTE!** Metal oxide semiconductor sensors are not replaceable!



## Maintenance

Do not perform any maintenance operation with the power on.

Clean the device with a soft damp cloth. Do not use any abrasive cleaning agents. Do not immerse the device in water or any cleaning media.

## Calibration

E2630-VOC detectors have been calibrated by the Manufacturer with standard gas mixtures before delivery. Provided that the sensor is used under moderate conditions, field recalibration is recommended every 12 months. Please contact your dealer for more information.

## Delivery set

- Carbon Monoxide Detector E2630-VOC
- Mounting accessories:
  - 4 screws and 4 plastic dowel plugs

## Order code for E2630-VOC options

E2630 options	Order code
Integrated 90...265 V mains power supply module	E2630-VOC-230
Integrated 24 VAC power supply module	E2630-VOC-24VAC

## Warranty

This product is warranted to be free from defects in material and workmanship for a period of one year from the date of the original sale. During this warranty period, the Manufacturer will, at its option, either repair or replace a product that proves to be defective. This warranty is void if the product has been operated in conditions outside ranges specified by the Manufacturer or damaged by customer error or negligence or if there has been an unauthorized modification.

## Manufacturer contacts

Evikon MCI OÜ

Teaduspargi 7/9, Tartu

50411 Estonia

info@evikon.eu

www.evikon.eu

